

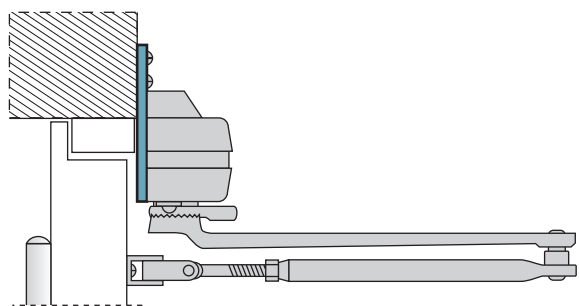

AC 56
Piastra di abbassamento.
Drop plate.

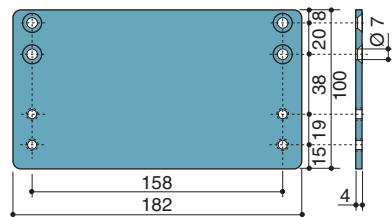

AC 55
Piastra angolare.
Bracket.

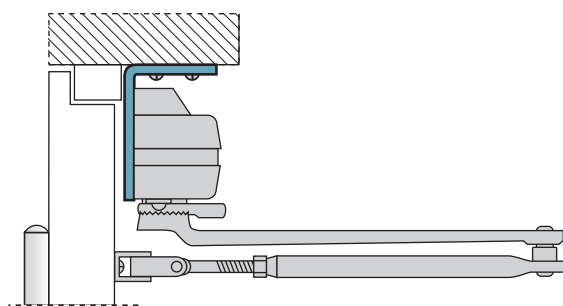
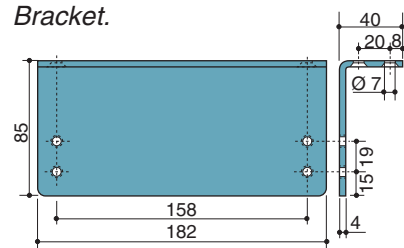

AC 566
Piastrina di innalzamento.
Shoe attachment plate.

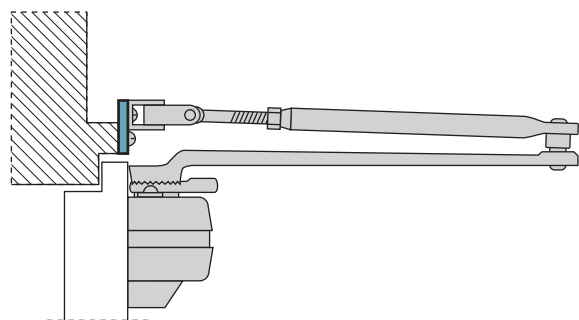
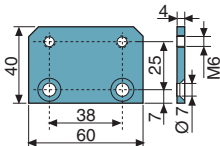

AC 220
Cavaliere per montaggio su porte in vetro temperato.
Clip-on plate for tempered glass doors.

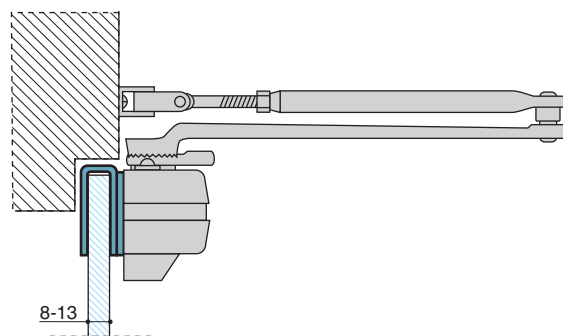
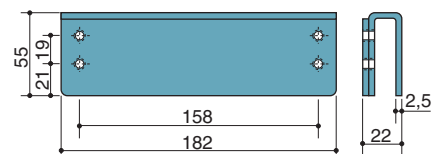

SPECIFICA PER CAPITOLATI.
Chiudiporta multiforza EN 2-5 con fermaporta integrato regolabile, MAB 564.

SPECIFICATION.
Variable power EN 2-5 door closer with integrated adjustable hold open, MAB 564.

G.R. GRAFICA E PUBBLICITA' - LZ - 09-2003 - copie 2000

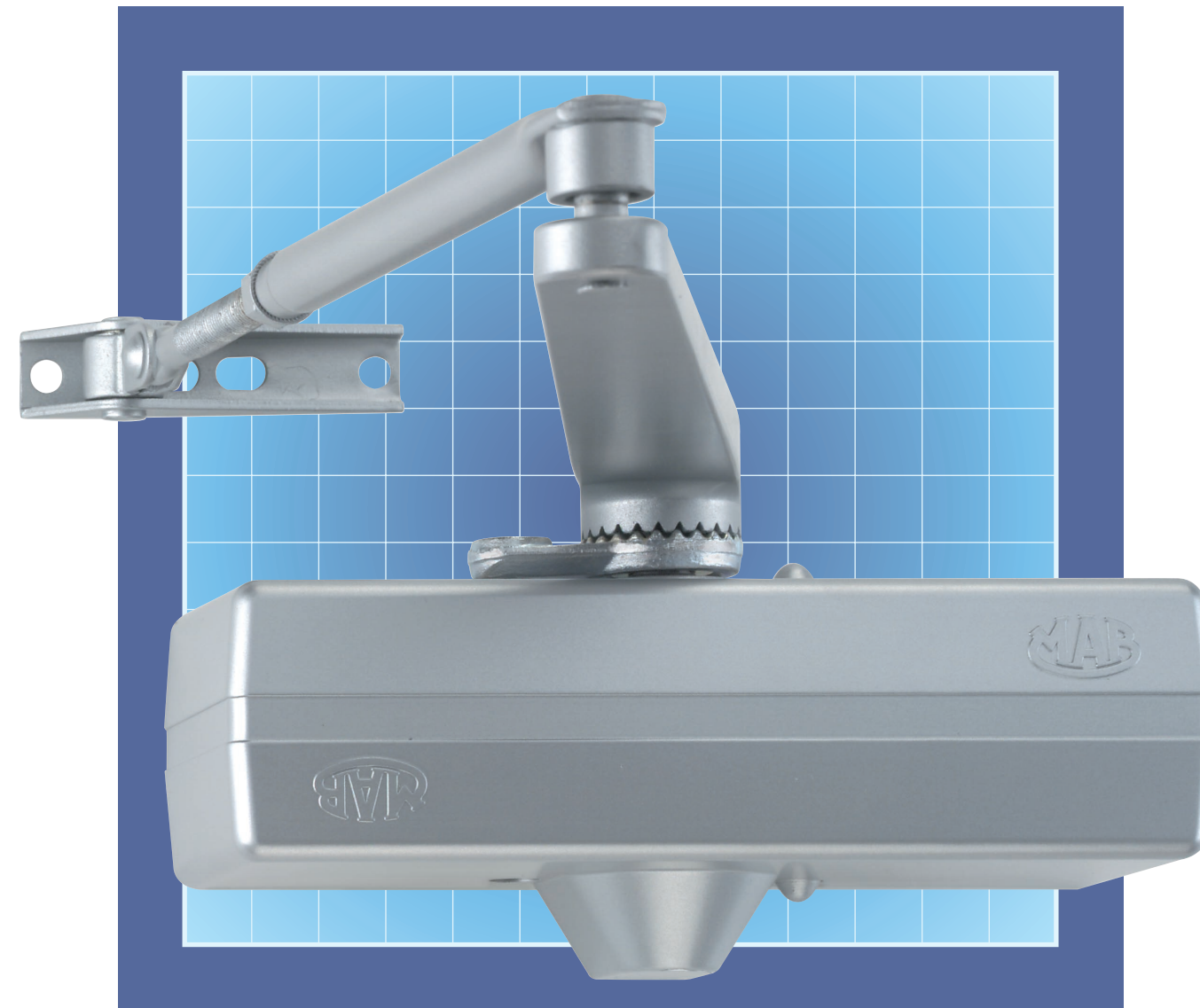

**CHIUDIPIORTA
MULTIFORZA
CON FERMO
REGOLABILE**

564

**VARIABLE POWER
DOOR CLOSER
WITH ADJUSTABLE
HOLD OPEN**



CHIUDIORTA MULTIFORZA CON FERMO REGOLABILE

564

VARIABLE POWER DOOR CLOSER WITH ADJUSTABLE HOLD OPEN

CARATTERISTICHE:

- **Unico corpo** in ghisa per tutte le forze.
- **Custodia** di finitura in ABS ad alta resistenza.
- **Forza** di chiusura variabile **EN 2-5**.
- **Fermaporta integrato** di facile e precisa regolazione.
- **Velocità di chiusura** 180° - 10° circa, regolabile con valvola termostatica non critica. In caso di regolazione senza scatto assicura un controllo su tutto l'arco di chiusura.
- **Scatto finale** da circa 10°. L'angolo di scatto è facilmente modulabile da un braccetto a doppio tenditore fino alla sua eliminazione completa (chiusura dolce). La possibilità di scatto potente anche da angolo ridotto a pochi gradi, garantisce la chiusura anche in caso di serrature con scrocci particolarmente duri.
- **Ampia** disponibilità di accessori per risolvere qualsiasi problema di montaggio.
- **Finiture di serie:** argento, oro, bronzo chiaro, nero opaco, avorio RAL1013, bianco RAL 9016. Altre finiture possono essere disponibili a richiesta.

FEATURES:

- **One body size** in high duty cast iron for all sizes.
- **Cover** in special impact resistant ABS.
- **Variable closing force sizes EN 2-5**.
- **Integrated hold open device** easily adjustable precisely to the desired angle.
- **Closing speed** 180° - 10° adjustable by non critical thermostatic valve which, in case of Without-Final-Latch setting of the arm, controls the complete arc of closing.
- **Final latch** from approx. 10°. The latch angle is easily reduced by turning the forearm, up to its elimination (soft closing). The possibility to ensure a powerful latch also from an arc of just a few degrees guarantees reduced noisy action in case of hard-to-latch locks.
- **Wide range** of accessories to make all mountings possible.
- **Standard finishes:** silver, gold, light bronze, mat black, oyster white RAL1013, traffic white RAL 9016. Other finishes may be available on request.

COME VARIARE LE FORZE.

La posizione di montaggio del corpo e il fissaggio del piedino determinano le forze 2-3-4-5.

HOW TO SET THE CLOSING FORCE.

The mounting location and the attachment shoe position determine the closing forces 2-3-4-5.

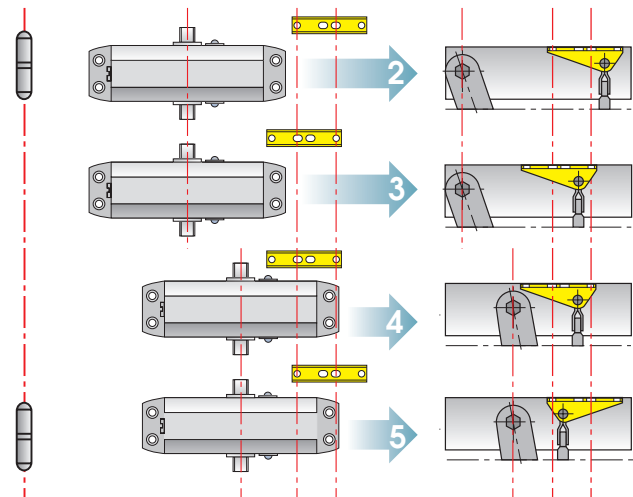

DIMENSIONI MASSIME CONSIGLIATE DELLE PORTE.

In caso di porte soggette a vento o a correnti d'aria, selezionare la forza superiore.

RECOMMENDED MAXIMUM DOORS SIZES.

In case of doors subject to wind or air draught, select the next higher size.

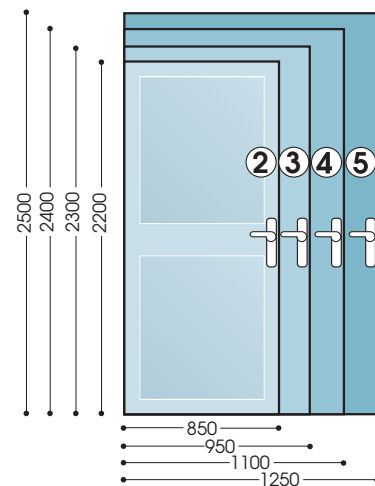

Norma europea EN 1154: momento di chiusura tra 0° e 4°	Forza Force	Larghezza max. porta Max. door width	EN richiede EN requires	Mod. 564
European standard EN 1154: closing moment between 0° and 4°	2	850 mm.	≥ 13 Nm	≥ 16 Nm
	3	950 mm.	≥ 18 Nm	≥ 20 Nm
	4	1100 mm.	≥ 26 Nm	≥ 30 Nm
	5	1250 mm.	≥ 37 Nm	≥ 40 Nm

REGOLAZIONE DELLA VELOCITÀ DI CHIUSURA (180°-10°).

CLOSING SPEED ADJUSTMENT (180°-10°).

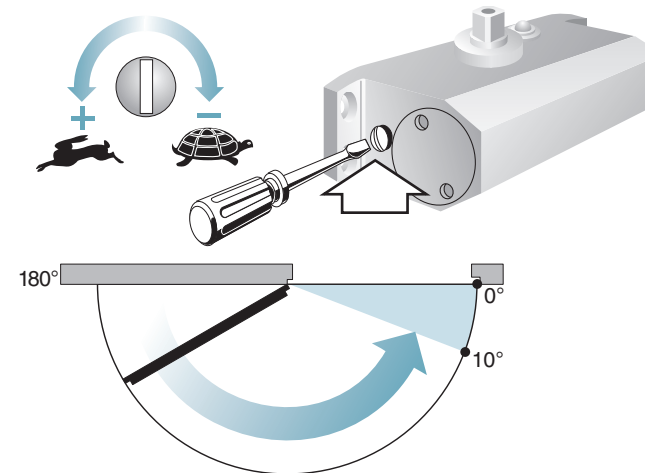

REGOLAZIONE DELL'ANGOLO DI SCATTO FINALE (10°- 0°).

ADJUSTMENT OF FINAL LATCH ANGLE (10° - 0°).

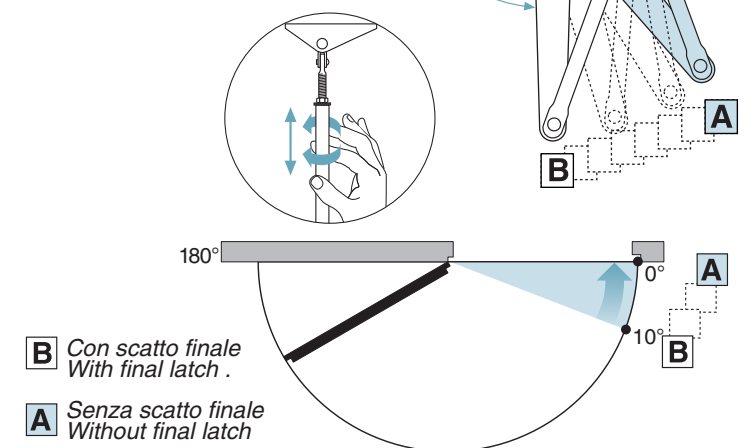

- B** Con scatto finale
With final latch.
- A** Senza scatto finale
Without final latch

FERMAPORTA ESCLUSIVO MAB.

Il movimento solidale del braccetto con il pignone rende possibile una potente azione di fermo tra 70° e 140°. Per la sua efficacia è particolarmente indicato per porte **ESTERNE**.

MAB UNIQUE ADJUSTABLE HOLD OPEN DEVICE.

Being connected to the pinion, the shim ensures a strong hold open action between 70° and 140°. Recommended for **EXTERIOR** doors.

Braccetto fermaporta.
Hold open Shim.
Perno fermaporta.
Hold open Pin.

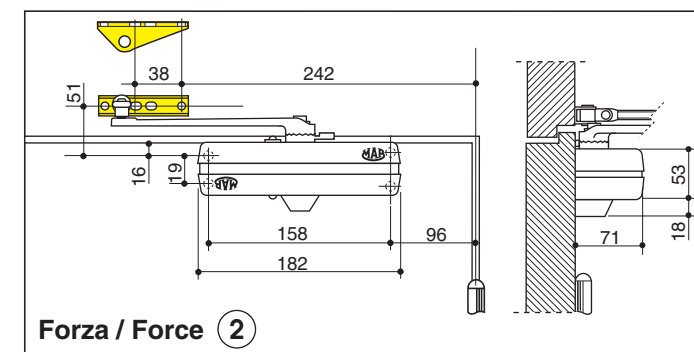
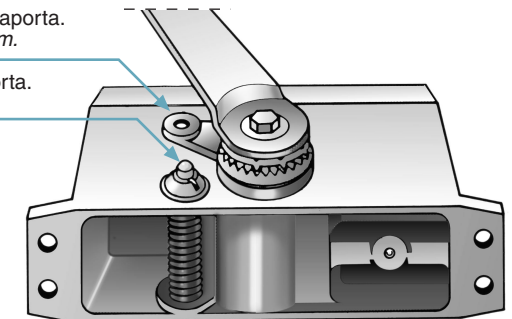

Forza / Force ②

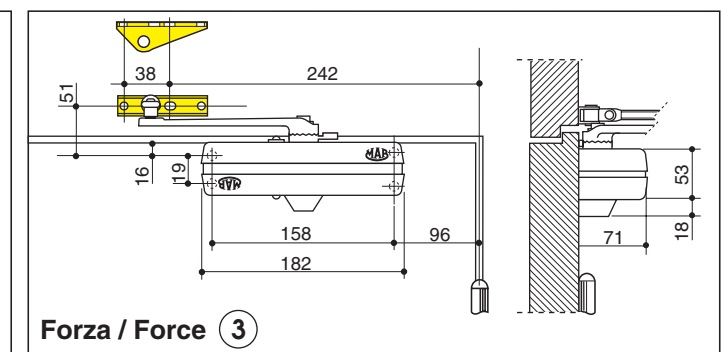

Forza / Force ③

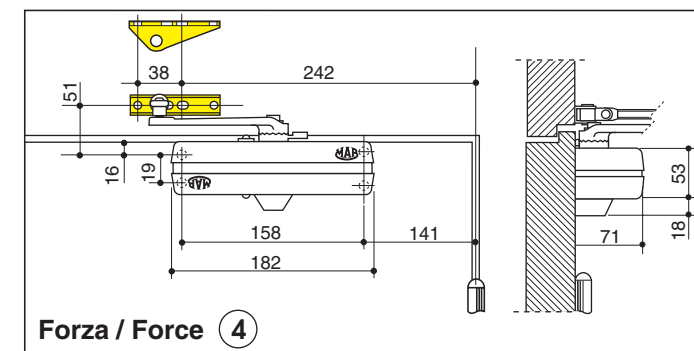

Forza / Force ④

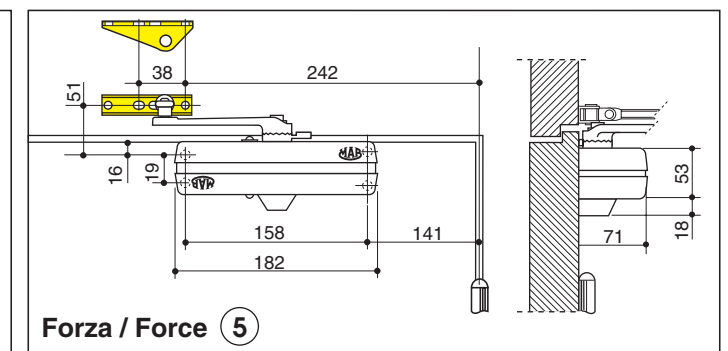

Forza / Force ⑤

MONTAGGIO NORMALE LATO CERNIERE. STANDARD MOUNTING PULL SIDE.

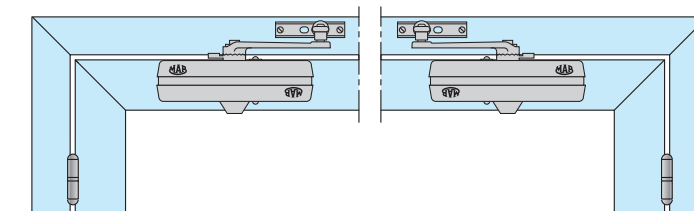

MONTAGGIO ROVESCiato LATO OPPOSTO CERNIERE. REVERSED MOUNTING PUSH SIDE.

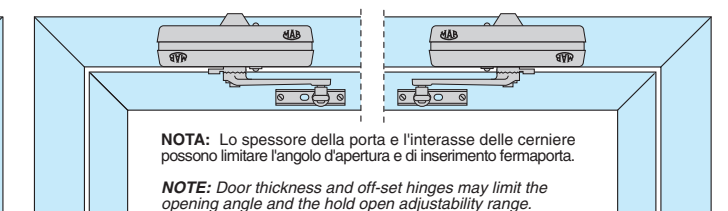

NOTA: Lo spessore della porta e l'interasse delle cerniere possono limitare l'angolo d'apertura e di inserimento fermaporta.
NOTE: Door thickness and off-set hinges may limit the opening angle and the hold open adjustability range.